

# JASOPELS SKIN CLEANER T3

ITEM NO. 32300014

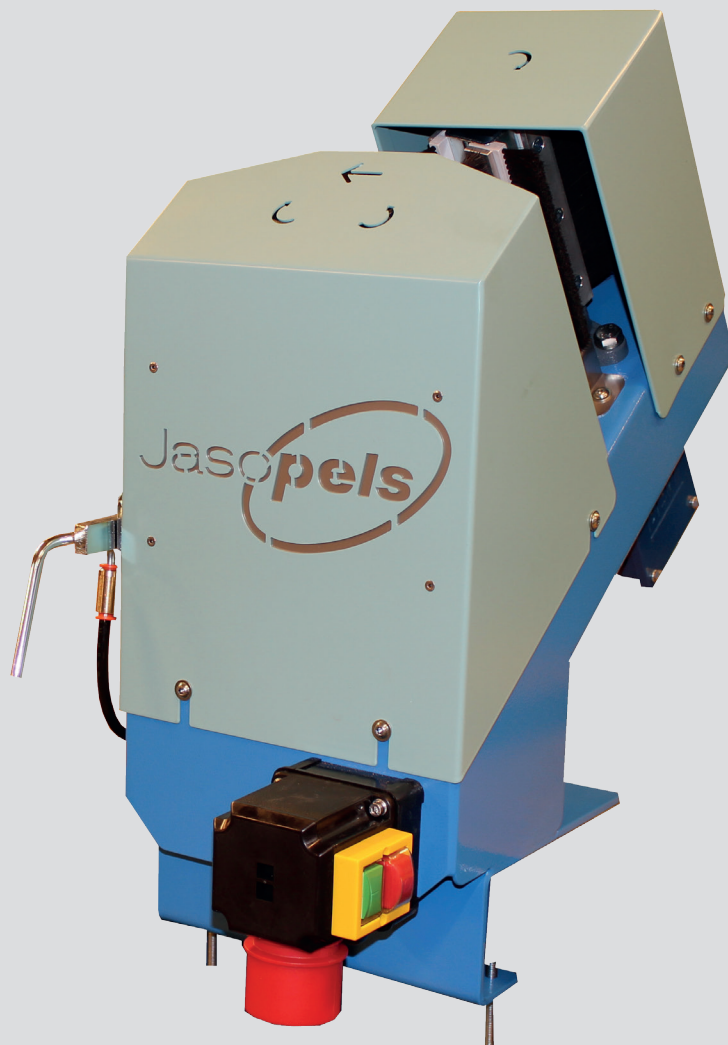

Our quality – Your choice





## TABLE OF CONTENTS

---

Preface.....	3
Declaration of Conformity.....	5
Symbol explanation .....	6
Introduction to the machine.....	7
Start-up.....	7
Operation .....	8
Replacement of belt .....	9
Maintenance .....	10
Technical data .....	10
Spare part list .....	11
User's note .....	12

## PREFACE

---

- This User Manual is an important part of your new machine. Read the manual carefully and use it as a reference book.
- This manual contains important information about safety and the proper use of the machine.
- The manual should be stored with the machine. It is important that the user manual is supplied with the machine upon resale and loan out.
- The owner of the machine must make sure that the operator, service personnel and others who have access to the machine are instructed on the proper use and handling of the machine. Read this user's manual for more information.
- Unauthorized modifications, additions or changes on the machine are not permitted for reasons of overall safety. Neither the manufacturer nor the vendor can be held responsible for damage that occurs because of the above mentioned. Any risk arising of unauthorized use is solely the end user's responsibility.



# DECLARATION OF CONFORMITY

---

## EU DECLARATION OF CONFORMITY

Type: 52-0000  
Machine: Skin Cleaner T3

Manufacturer:  
Name: Jasopels A/S  
Address: Fabriksvej 19  
Town: Dk-7441 Bording  
Tel. +45 98 42 05 66

**JASOPELS A / S DECLARES THAT THIS PRODUCT IS IN ACCORDANCE WITH THE FOLLOWING EU DIRECTIVES:**

2006/42/EC  
2006/95/EC  
2006/108/EC

**FURTHERMORE, WE DECLARE THAT THE FOLLOWING HARMONIZED STANDARDS HAVE BEEN APPLIED:**

- EN 60204-1
- DS/EN 12100 : 2005
- DS/EN 14121-1
- DS/EN 14121-2

### STATEMENT ISSUED BY:

Name: Poul A. Bach  
Company: Jasopels a/s  
Address: Fabriksvej 19  
Town: DK-7441 Bording

Signature:



Date: January 31, 2010

**CEO, Poul A. Bach, Fabriksvej 19, DK-7441 Bording, is entitled to supply technical files.**

Updated: August 9, 2016

## SYMBOL EXPLANATION

---

- Please read this manual and follow the instructions. In order to emphasize certain information, the following expressions are used:

**NOTE!!**



A triangle containing an exclamation mark is a warning symbol that warns you of important instructions or information concerning this machine.

**DANGER!!**



A triangle containing a lightning bolt is a warning symbol that warns of "High Voltage".

**WARNING!!**



A triangle containing a warning about an entanglement and crush hazard.

## INTRODUCTION TO THE MACHINE

---

- BS Skin Cleaner Type 3 is designed for the softening of mink skins.
- After having been treated in this machine they are soft and fluffy, ready for auction.
- The machine is easy and simple to use.

### Note!

- The user's manual has to be read before the machine is used.
- The owner of the machine must make sure that the operator, service personnel and others who have access to the machine are instructed on the proper use and handling of the machine.
- The machine may only be used for the purpose it is designed for.
- Under no circumstances may faults in the machine or its operation – no matter what they are – be corrected before the machine has been properly switched off, unless a minor correction can be made through the machine's operation buttons.
- The user manual must always be kept available for the operator.



## START-UP

---

- Before start-up the machine has to be mounted onto a table. The machine is pushed up to the edge of the table, then the two bolts are fastened tightly under the table top. Make sure that the machine is fastened to the table before it is started.
- In the factory the machine has been assembled with a 5-poled 16 A CEE plug at the end of the power supply cable and can be connected to an outlet with 3P+N+PE. At the side of the skin cleaner a valve has been installed with a quick coupling where the compressor's tube is connected.
- Connect a vacuum cleaner under the machine, the tube on the machine fits into the hose of a vacuum cleaner. This removes loose hair and sawdust from the skins' outside and does not hurl them into the room.
- The skin cleaner is now ready for use.



### DANGER!

Switch off the compressed air and the power supply before starting on any maintenance, cleaning or other service on the machine.



In order to avoid possible damage of the electrical system in connection with thunderstorms it is advisable to disconnect the electrical connections when the machine is not used.



**DANGER!**

Avoid wearing loose clothing as there is a risk of entanglement. It is advisable to wear hair net in case of long hair.



## OPERATION

After having been connected the skin cleaner is ready for use. Turn on the air and suction before starting the machine.



On the front of the machine there is a switch. Start the machine by pressing the green button and stop it by pressing the red.

Never operate the machine without suction, because this will whirl dust and sawdust into the room. Standing in front of the skin cleaner the skin is run through the machine from the right to the left with its back turned towards the operator.

Take the mink's head in your left hand and its tail in your right. The mink's head is run in between the brushes and followed by the skin with a firm pull, at an angle down towards the left (in the drawing: down towards the right). This is done in order to soften the skin over the last brushes.

Skin feeding

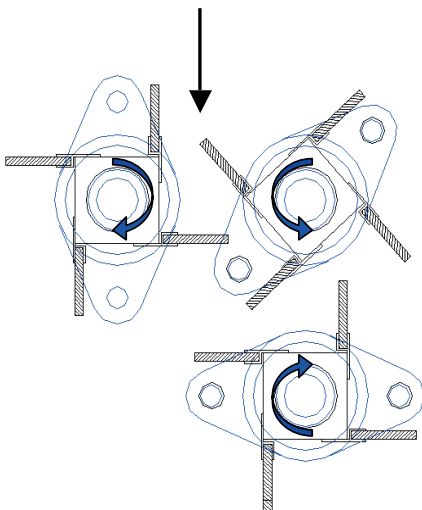

Keep the skin taut by holding back on the tail. Run the skin through the machine at an even speed to avoid stripes.



After the skin has been run through the skin cleaner there will be a certain amount of sawdust in the skin. At one side of the machine there is an air branch over which the skin is pulled. The air branch is activated by pressing it slightly upwards, now the skin is blown clean from the inside.



Air branch

After this the skin is ready for delivery!

## REPLACEMENT OF BELT

### DANGER!

Switch off the compressed air and the power supply before starting on any maintenance, cleaning or other service on the machine.



The belt has to be mounted in the following way:

- To begin with remove the screen at the back of the skin cleaner.
- Now the belt can be removed. The belt can be loosened with the help of the tension pulley

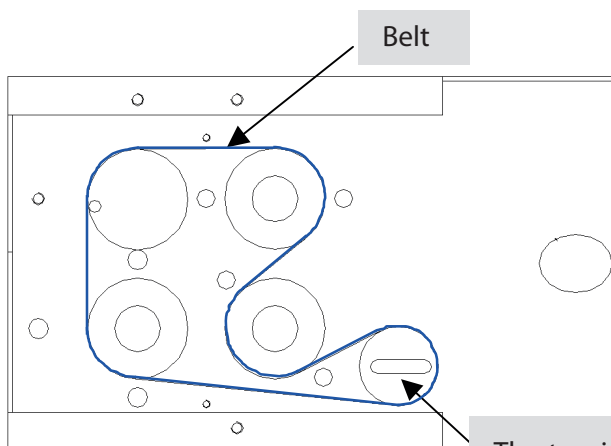

The tension pulley is eccentric. Turn for adjustment.

- Put the new belt into its place according to the following drawing.
- Remember to tighten the belt again using the tension pulley.
- Finally put the screen back into its place.

## MAINTENANCE

---

### DANGER!

If you need to do maintenance work inside the drum, the power cable and compressed air hose **MUST** be removed.

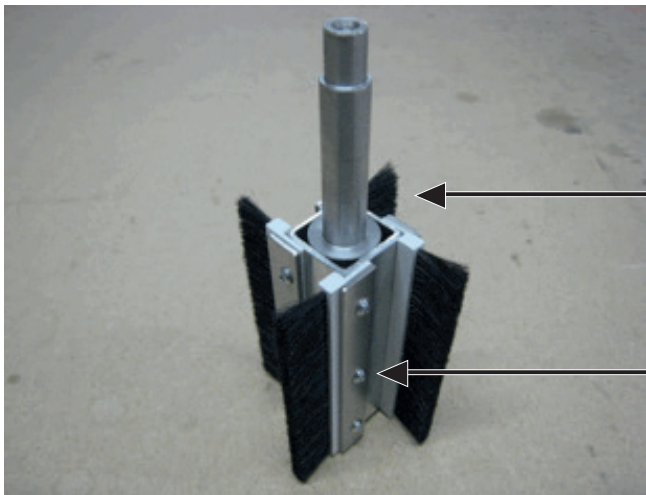

### Spare part

51900022

Brush for Skin cleaner 150 mm

Loosen the 3 screws with a 4 mm unbraco key

Skin cleaner is mainly maintenance-free, but there will always be a certain wear on the brushes. When the brushes have to be exchanged, it is done in the following way:

- Disconnect the air and power supply.
- Screw off the screens.
- Each of the 12 brushes has been attached by 3mm unbrako bolts. Unscrew the 3 bolts, remove the old brushes, put a new on and tighten the 3 bolts again.
- Screw the screens back.
- Reconnect air – and power supply and continue with your work.

At the end of the season the machine has to be cleaned, this is done with compressed air and water. After having been cleaned all the lubricating nipples on the bearing have to receive a single press with a grease press.

## TECHNICAL DATA

---

- Electrical connection: 3 x 400 V + PE 5 poled CEE plug
- Power: 1,2 A
- Air connection: Quick coupling
- Air consumption: Max 8 bar. 1 l/min.
- Measurements: Height 55 cm  
Length 28 cm  
Width 63 cm

## SPARE PART LIST

---

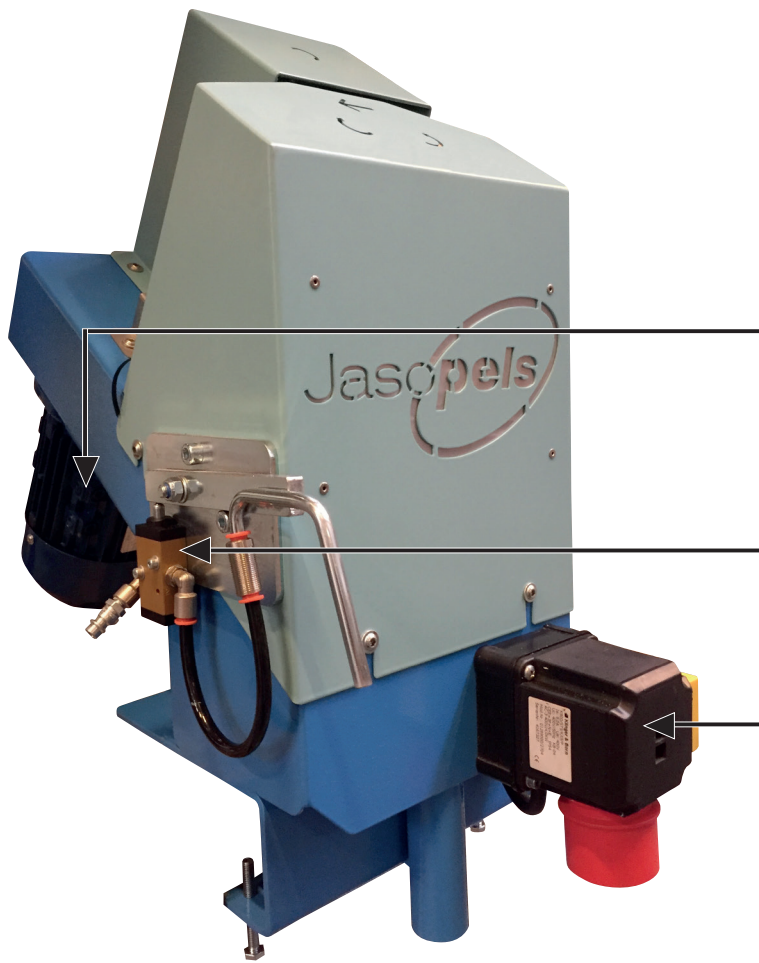

**Spare part**  
59300155  
Engine

**Spare part**  
59100122  
Valve

**Spare part**  
59200515  
Engine starter Skin cleaner T3







## Our quality – Your choice

Fabriksvej 19 • DK-7441 Bording • Tel. +45 98 42 05 66 • [info@jasopels.com](mailto:info@jasopels.com) • [www.jasopels.com](http://www.jasopels.com)

Varenr. 32300045



32300045